

Technical sheet :

MRT-X 3570

VISION +



 **MANITOU**
HANDLING YOUR WORLD

Get in touch today for sales enquiries or further information

CONTACT US



0800 30 30 90

abequipment.co.nz



Capacities		Metric
Max. capacity		7000 kg
Max. lifting height		34.70 m
Max. outreach		28 m
Weight and dimensions		
Overall width	b1	2.50 m
Overall height	h17	3.26 m
Overall cab width	b4	0.96 m
Ground clearance	m4	0.36 m
Wheelbase	y	3.75 m
Tilt-up angle	a4	11 °
Tilt-down angle	a5	113 °
Turret rotation		360 °
Overall weight		23800 kg
Forks length / width / section	l / e / s	1200 mm x 125 mm x 60 mm
Wheels		
Standard tyres		17,5_R25
Drive wheels (front / rear)		2 / 2
Steering mode		2 wheel steer, 4 wheel steer, Crab mode
Stabilisers		
Stabs Type		Telescopic Triplex
Controls with stabs		Stabs Commands Individual or Simultaneous
Engine		
Engine brand		Yanmar
Engine nom		Stage V / Tier 4
Engine model		4TN107FTT-6SMU2
I.C. Engine power rating / Power (kW)		211 Hp / 155 kW
Max. torque / Engine rotation (min)		805 Nm @ 1500 rpm
Number of cylinders - Capacity of cylinders		4 - 4567 cm³
Engine cooling system		Water cooled
Number of batteries / Battery / Batteries capacity		2 x 12 V / 120 Ah
Battery starting current		(EN)850 A
Transmission		
Transmission type		Hydrostatic with CVT
Gearbox		Speedshift
Max. travel speed		40 km/h
Parking brake		Automatic negative parking brake
Service brake		Oil-immersed multi-discs braking on front & rear axles
Hydraulics		
Hydraulic pump type		Variable displacement pump
Hydraulic flow		185 l/min
Hydraulic Pressure		350 bar
Tank capacities		
Engine oil		13 l
Hydraulic oil		300 l
Fuel tank		320 l
Miscellaneous		
Steering wheels (front / rear)		2 / 2
Controls		2 Joysticks
Safety cab homologation		Cabin ROPS - FOPS Level 2
Attachment recognition system (E-Reco)		Standard

MRT-X 3570 - Dimensional drawing

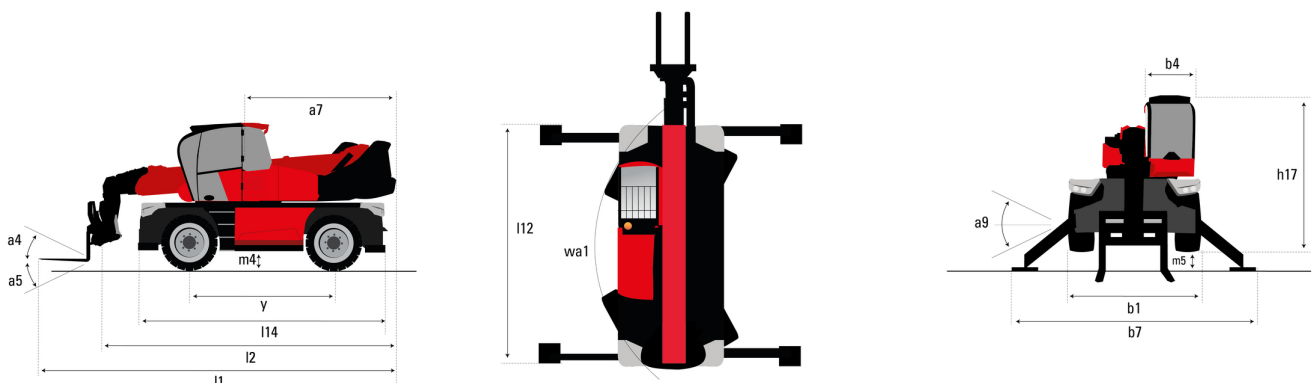

Other data		Metric
Overall length (with forks)	l1	10.06 m
Length to face of forks	l2	8.86 m
Length of frame	l14	6.82 m
Wheelbase	y	3.75 m
Ground clearance	m4	0.36 m
Counterweight offset (turret at 90°)	a7	3.74 m
Tilt-up angle	a4	11 °
Tilt-down angle	a5	113 °
Overall length at stabilisers	l12	6.49 m
External turning radius (over tyres)	Wa1	4.91 m
Overall width	b1	2.50 m
Overall width with stabilisers extended	b7	7.40 m
Overall cab width	b4	0.96 m
Overall height	h17	3.26 m
Frame levelling corrector	a9	+/- 8 °
Ground clearance under front tires on stabilizers	m5	0.45 m

MRT-X 3570 - Load chart

Machine on tyres with forks Metric

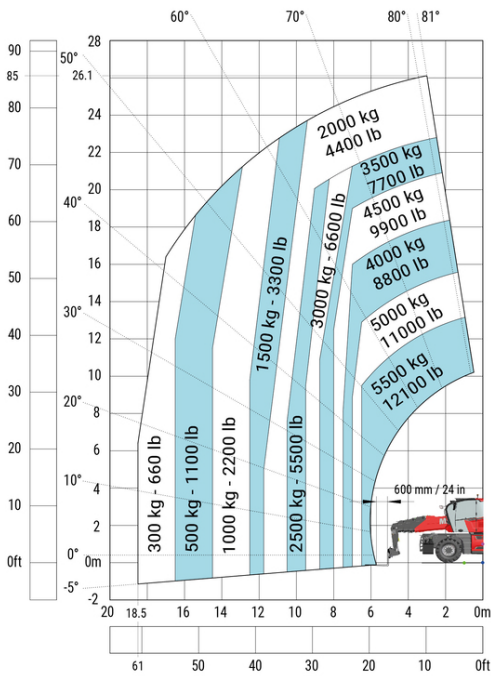

Machine on lowered stabilisers with forks Metric

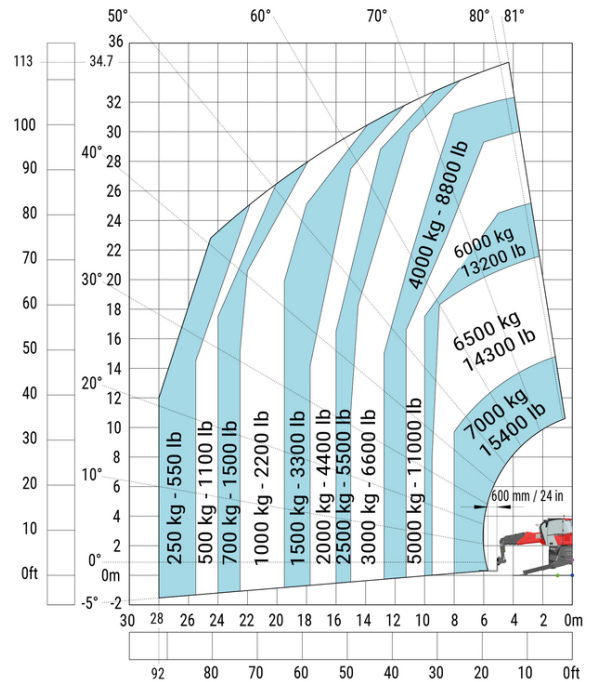

Machine on lowered stabilisers with 1500 kg jib Metric

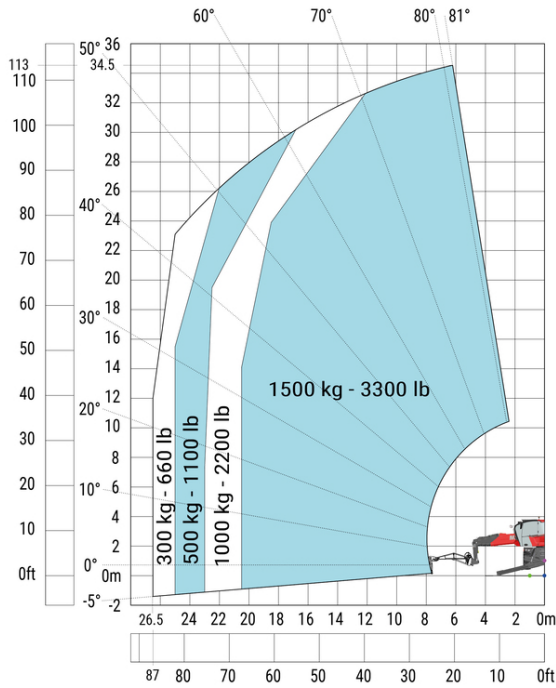

Machine on lowered stabilisers with 365 kg platform Metric

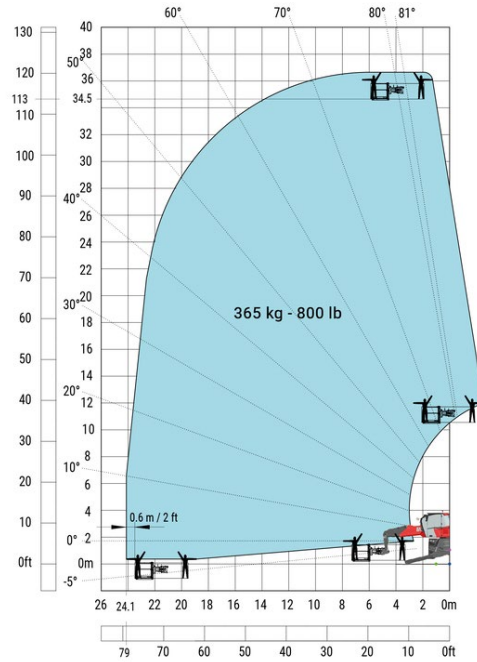

Machine on lowered stabilisers with 3D positive Metric

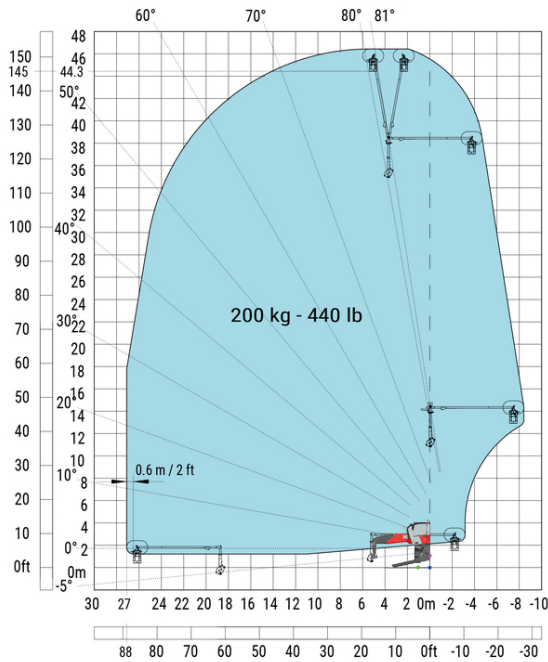

Machine on lowered stabilisers with hook 9000 kg (Metric)

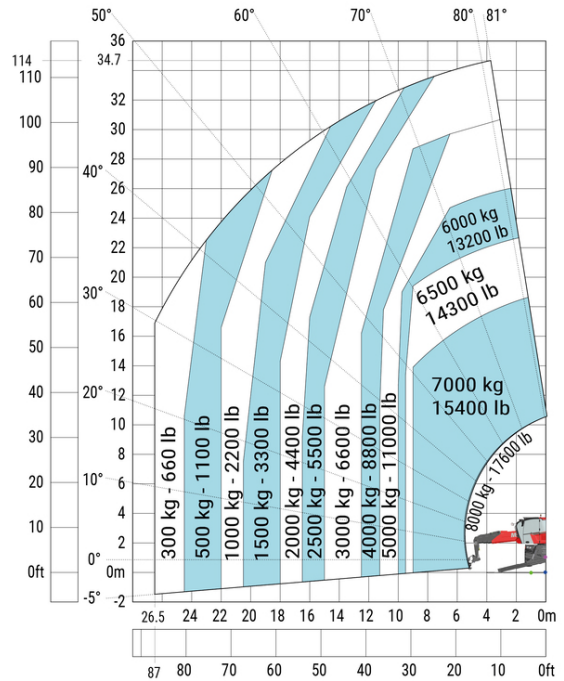

Machine on lowered stabilizers with winch 7200 kg (metric)

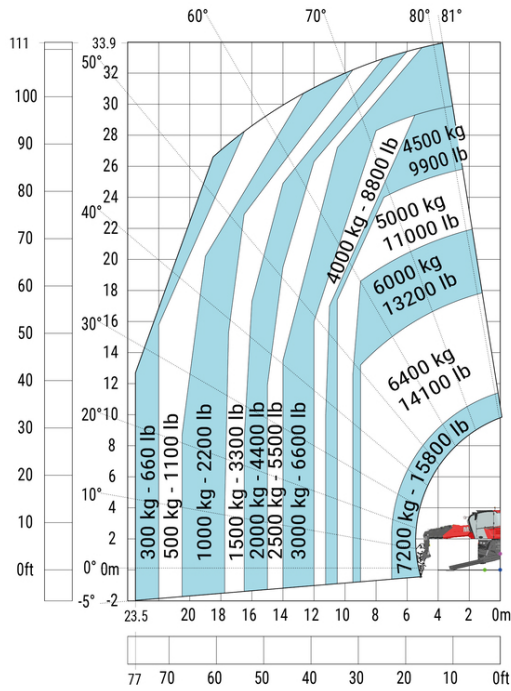

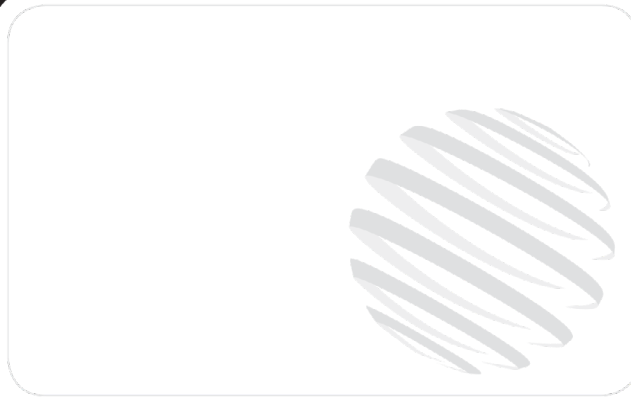

Siège Social
430 rue de l'Aubinière - 44150 Ancenis Cedex - France
Tel: +33(0)2 40 09 10 11 - Fax: +33 (0)2 40 09 10 97
www.manitou.com



This brochure describes versions and configuration options for Manitou products which may be fitted with different equipment. The equipment described in this brochure may be standard, optional or not available depending on version. Manitou reserves the right to change the specifications shown and described at any time and without prior warning. The manufacturer is not liable for the specifications given. For more information, contact your Manitou dealer. Non-contractual document. Product descriptions may differ from actual products. List of specifications is not comprehensive. The logos and visual identity of the company are the property of Manitou and may not be used without authorisation. All rights reserved. The photos and diagrams contained in this brochure are provided for information only.

MANITOU BF SA - Limited company with board of directors - Share capital: 39,668,399 euros - 857 802 508 RCS Nantes

Get in touch today for sales enquiries or further information

CONTACT US



0800 30 30 90

abequipment.co.nz

