

## MAIN SPECIFICATIONS

Model		FGZN20	FDZN20	FGZN25	FDZN25	FGZN30	FDZN30
Engine Model		4Y Gasoline	1DZ-II Diesel	4Y Gasoline	1DZ-II Diesel	4Y Gasoline	1DZ-II Diesel
Load Capacity	kg	2000		2500		3000	
Load Center	mm	500		500		500	
Overall Width	A mm	1150		1150		1255	
Turning Radius (outside)	B mm	2200		2260		2400	
Overhead Guard Height	C mm	2130		2130		2195	
Length to Fork Face	D mm	2570		2650		2770	

## ENGINE SPECIFICATIONS

Model		TOYOTA 4Y Gasoline	TOYOTA 1DZ- II Diesel
Piston Displacement	cc	2237	2486
Rated Power/r.p.m.	kW	30/2000	35/2200
Rated Torque/r.p.m.	N-m	153/1600	156/2100

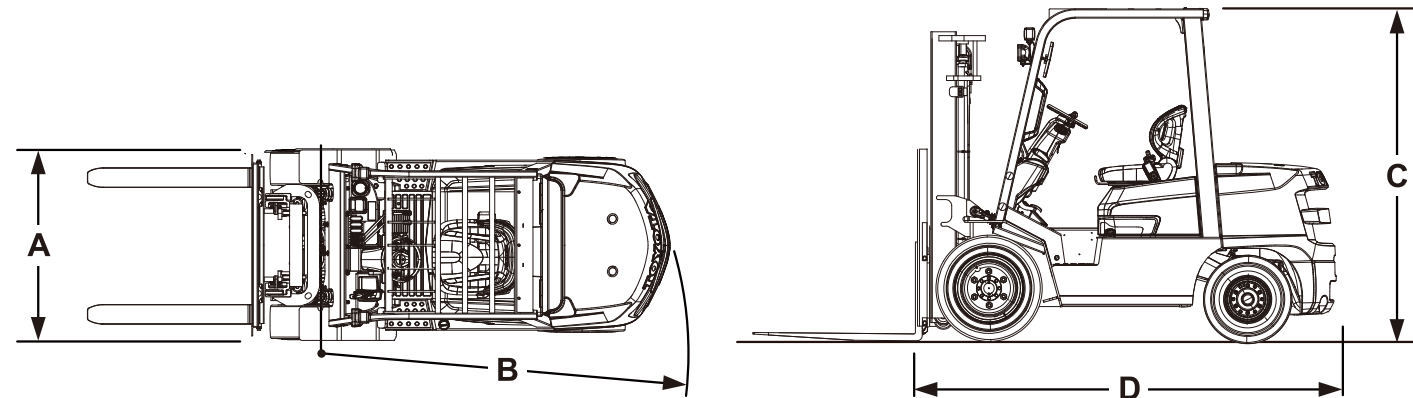

The data in this brochure was determined based on our standard testing conditions. Operating performance may vary depending on the actual specifications and condition of the vehicle, as well as the conditions of the operating area.  
 Due to photography and printing, the color of actual vehicle may vary from this brochure. Some photos have been computer-enhanced.  
 Availability and specifications are determined by market and are subject to change without notice.  
 Safe forklift operation is achieved by proper operator training and proper worksite rules. Please consult your Toyota representative regarding forklift selection and operator training.  
 Please consult your Toyota representative for details.

All rights reserved by Toyota Industries Corporation.

ENGINE POWERED FORKLIFT

2.0 to 3.0 TON

# FGZN/FDZN SERIES





# SIMPLE AND TOUGH

**FGZN/FDZN SERIES**  
ENGINE POWERED FORKLIFT 2.0 to 3.0 TON

We bring to you the FGZN/FDZN Series, which continues the tradition of quality cultivated more than 60 years of history of the Toyota forklifts.





# THE SAME HIGH QUALITY AS ALWAYS

The FGZN/FDZN Series continues the tradition of high quality with reliable components.

We're supporting your operations with durable, high-quality products that you can use whenever you want.



Features and equipment may vary depending on market.

## High-quality Key Components

**Active on several type of application and ready for use whenever you want**

The Toyota-built engine is equipped, demonstrating good performance quickly when the ignition key is turned on. This provides rapid response and high work efficiency for your operations.

**Active at a variety of worksites with excellent durability and reliability**

The reliable components enable the operator to accomplish travelling, load handling, unloading, and other tasks just as intended, and deliver stable performance even over many hours of operation.

### TOYOTA-BUILT ENGINE



The 1DZ-II is shown



#### Transmission

Stable Performance and Smooth Power Transmission

Transmission of burly power to the wheels

#### Hydraulic Components

Stable Performance with High Reliability and Durability

Agile control for lift and tilt operations

#### Control Valves

Precise Control with High Reliability and Durability

Accurate control of hydraulic oil flow



# FGZN/FDZN SERIES

Features and equipment may vary depending on market.



## CONTINUATION OF SAFETY

The body design continuing Toyota's safety concepts enhances lateral stability through measures such as the addition of the damper to the rear axle.

### Load-handling Feature

#### Key-lift Interlock

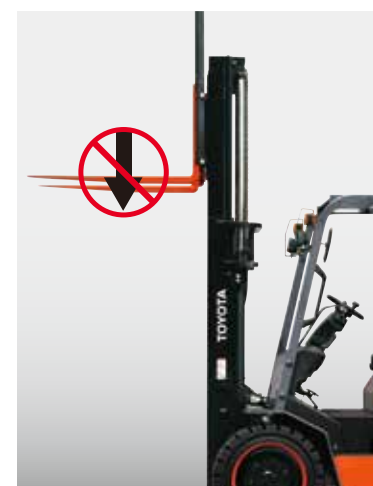

When the key is switched off the forks do not descend even if the load-handling levers are operated. This can help prevent accidents caused by unintended operation by someone other than the operator.

### Outstanding Visibility

#### Lattice-design Headguard



The headguard uses a lattice design that combines outstanding upward visibility and strength.

### Safe for Operator and Worksite



#### Stable Design for the Vehicle Body

The use of a rear axle damper helps ensure lateral stability and supports safe operation.



#### NEW Orange Seatbelt **OPT**

The color of the seatbelt to be orange, making it easier to confirm if the seat belt is securely fastened.

#### NEW Seatbelt Interlock System **OPT**

The forklift does not move unless the seatbelt is properly fastened.



#### NEW Blue Lights **OPT**

A blue beam of light appears on the ground to inform pedestrians of the forklift's presence, and helps to prevent accidents.

## Operator Presence Sensing System **OPT**



### OPS Feature



An Operator Restraint System (ORS) seat using patented Toyota technology is optionally available. This seat is mounted when the Operator Presence Sensing (OPS) system has been selected.

The OPS system uses a switch sensor built into the ORS seat to detect the presence of the operator. If the operator is not in the normal operating position, travel power is interrupted and load-handling operations are stopped. When the OPS controller detects that the seat switch is off, an audible alarm (beep) will sound and the OPS indicator light will turn on.

Note: OPS does not operate the brakes. Always set the parking brake before leaving the forklift.

### Leak-lock System



A check valve in the control valve reduces the amount of spontaneous fork descent and forward tilt. This feature is installed when the OPS system is selected.



# OPERATOR-FRIENDLY DESIGN

The FGZN/FDZN Series continues Toyota's operator-friendly design concepts, helping to reduce operator fatigue and contributing to comfortable operation.

## Small-diameter Steering Wheel



The small-diameter steering wheel teams up with the full hydraulic power steering system to provide excellent maneuverability. The steering column offers stepless adjustment to accommodate a wide range of operator preferences.

## Large Assist Grip **OPT**

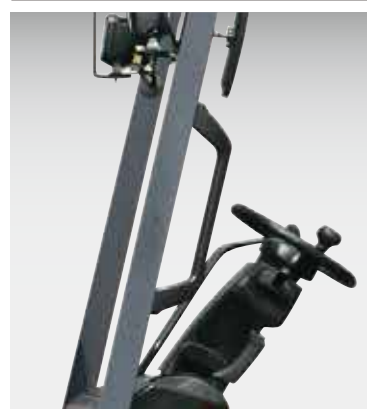

The large assist grip (350 mm) offers easy use for operators of almost all sizes.



Features and equipment may vary depending on market.

## Spacious Operator Area



The design of the headguard and the seat that is adjustable forward and backward achieve a roomy space for the operator.

## Excellent Forward Visibility



The angled lower stay ensures a good view of the fork tips, which makes it easier to insert forks into the pallet on the ground.

## Combination Meter



This combination meter includes a water-temperature indicator, fuel meter, hour meter, engine oil-temperature warning, and other indicators, making it easy to check the state of the forklift.

## Double-action Parking Brake



The double-action parking brake is easy and convenient to use.



# EASY MAINTENANCE

The FGZN/FDZN Series helps to achieve easy maintenance through simple design.

## Engine Hood



The wide-opening engine hood supports easy access to the engine compartment for inspection or servicing.

## Floorboard

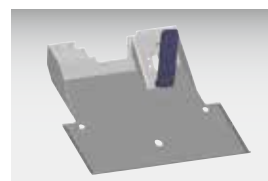

A two-piece design makes the floorboard easier to detach and handle. Removing the rear floorboard piece allows wide-open access to the engine and power train.

**NEW** LED Front Combination Lights **OPT**

**NEW** LED Rear Combination Lights **OPT**



These economical LED lights offer long life and low energy consumption.

# FRIENDLY TO THE OPERATING ENVIRONMENT

The FGZN/FDZN Series designed for low noise and low vibration makes your worksite more comfortable.



## Low-noise and Low-vibration Design

The Toyota-built engine and the floating design for the engine mounting achieve low levels of noise and vibration.

## Shockless Landing

The speed of fork lowering automatically slows down just before contacting the ground, contributing to reduce the noise.

Note: Only for the V Mast

# ENVIRONMENTAL PROTECTION

Continuing Toyota's environmental-conservation concepts, the FGZN/FDZN Series uses lead-free paint and plating free of hexavalent chromium, thereby contributing to the reduction of environmental impact and protection of the global environment.



Hexavalent  
Chrome-Free



Lead-Free

