

Pedestrian stacker truck 1.4 ton

BT staxio

P-series

SPE140S



TOYOTA

MATERIAL HANDLING

Pedestrian stacker straddle version

Specification for stacker trucks					SPE140S	
Identification	1.1	Manufacturer				BT
	1.2	Model				SPE140S
	1.3	Drive				Electric
	1.4	Operator type				Stand on/pedestrian
	1.5	Load capacity/rated load	Q	kg		1400
	1.6	Load centre	c	mm		600
	1.8	Load distance, centre of support arm wheel to face of forks	x	mm		758
	1.9	Wheelbase	y	mm		1454
	Weight	2.1	Service weight including battery		kg	
2.2		Axle load, with load, drive/castor/support arm wheel		kg		550/610/1779
2.3		Axle load, without load, drive/castor/support arm wheel		kg		330/687/522
Wheels	3.1	Drive/castor/fork wheel				Friction/Vulkollan®/Vulkollan®
	3.2	Wheel size, front		mm		Ø 230
	3.3	Wheel size, rear		mm		Ø 140/ Ø 85
	3.4	Additional wheel size		mm		Ø 125
	3.5	Wheels, number front/rear (x = driven wheels)				1x+2/2 or 4
	3.6	Track width, front	b ₁₀	mm		585
	3.7	Track width, rear	b ₁₁	mm		985*
Dimensions	4.2	Height, mast lowered	h ₁	mm		1946
	4.3	Free lift	h ₂	mm		1478
	4.4	Lift	h ₃	mm		4060
		Lift height	h ₂₃	mm		4100
	4.5	Height, mast extended	h ₄	mm		4668
	4.8	Stand height (optional platform)	h ₇	mm		190
	4.9	Height of tiller arm in drive position, min./max. highest setting	h ₁₄	mm		1201/1413
		lowest setting	h ₁₄	mm		1101/1313
	4.10	Height of support arm	h ₁₀	mm		140 or 93
	4.15	Height, fork lowered	h ₁₃	mm		50
	4.19	Overall length platform up	l ₁	mm		2115
		platform down	l ₁	mm		2548
	4.20	Length to face of forks platform up	l ₂	mm		965
		platform down	l ₂	mm		1398
	4.21	Overall width	b ₁ / b ₂	mm		790/1172*
	4.22	Fork dimensions	s/e/l	mm		40/100/1150
	4.25	Width over forks	b ₅	mm		250-890
	4.26	Distance between support arms	b ₄	mm		900*
	4.32	Ground clearance, centre of wheelbase	m ₂	mm		40/32,5
	4.33	Aisle width for pallets 1000x1200 crossways platform up	A _{st}	mm		2594
platform down		A _{st}	mm		3044	
4.34	Aisle width for pallets 800x1200 lengthways platform up	A _{st}	mm		2473	
	platform down	A _{st}	mm		2923	
4.35	Turning radius platform up	W _a	mm		1677	
	platform down	W _a	mm		2127	
Performance data	5.1	Travel speed, with/without load 6 km/h version		km/h		6,0/6,0
		8 km/h version		km/h		7,0/8,0
	5.2	Lift speed, with/without load		m/s		0,17/0,33
	5.3	Lowering speed, with/without load		m/s		0,45/0,45
	5.8	Max. gradeability, with/without load ¹⁾		%		8/12
	5.9	Acceleration time (over 10 m)		s		7,1
5.10	Service brake				Electromagnetic	
Electric motor	6.1	Drive motor rating (S2 60min)				1,8
	6.2	Lift motor rating (S3 15%)		kW		3
	6.4	Battery voltage, nominal capacity K _s		V/Ah		24/300
	6.5	Battery weight		kg		195-270
	6.6	Energy consumption acc to VDI cycle		kWh/h		1,078
	Others	8.1	Type of drive control			
8.4		Sound level at the driver's ear according to EN 12 053		dB (A)		66

¹⁾ Measured according to company standard.

*) Further alternatives are available and will produce other values.
Data is based on standard truck and small battery.

All data are based on table configuration. Other configurations may give other values. Truck performance and dimensions are nominal and subject to tolerances. Toyota Material Handling Manufacturing Sweden AB products and specifications are subject to change without notice.

Battery dependent dimensions

Dimensions				SPE140S		SPE140S with backrest			
				Battery		Lift out		Lift out	
						S	L*	S	L*
1.9	Wheelbase	y	mm	1454	1551	1454	1551		
4.19	Overall length	I ₁	mm	2115	2212	—	—		
			mm	2548	2645	2562	2659		
4.20	Length to face of forks	I ₂	mm	965	1062	—	—		
			mm	1398	1495	1412	1509		
4.33	Aisle width for pallets 1000x1200 crossways	A _{st}	mm	2594	2691	—	—		
			mm	3044	3141	3219	3316		
4.34	Aisle width for pallets 800x1200 lengthways	A _{st}	mm	2473	2570	—	—		
			mm	2923	3020	3098	3195		
4.35	Turning radius	W _a	mm	1677	1774	—	—		
			mm	2127	2224	2302	2399		
6.4	Battery voltage, nominal capacity K ₅		V/Ah	24/300	24/500	24/300	24/500		
6.5	Battery weight, min.—max.		kg	195-310	345-405	195-310	345-405		

* DIN battery will give same truck dimensions as for the large battery

Mast dimensions

Mast			Duplex Tele Panoramic View					Duplex HiLo					Triplex HiLo							
SPE140S	h ₂₃	Lift height (h ₁₃ +h ₃)	mm	2300	2750	3250	3650	4100	2300	2450	2750	3250	3650	4100	3650	3900	4100	4450	4750	5350
	h ₃	Lift	mm	2210	2660	3160	3560	4010	2210	2360	2660	3160	3560	4010	3560	3810	4010	4360	4660	5260
	h ₁	Height, mast lowered	mm	1737	1962	2212	2412	2637	1736	1811	1961	2211	2411	2636	1796	1879	1946	2062	2162	2362
	h ₂	Free lift, ground to top of forks	mm	—	—	—	—	—	1256	1332	1482	1732	1932	2156	1328	1410	1478	1594	1694	1894
	h ₄	Height, mast extended	mm	2892	3342	3842	4242	4692	2891	3041	3341	3841	4241	4691	4218	4467	4668	5016	5316	5916

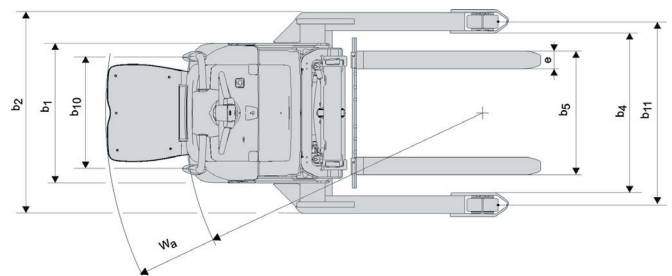
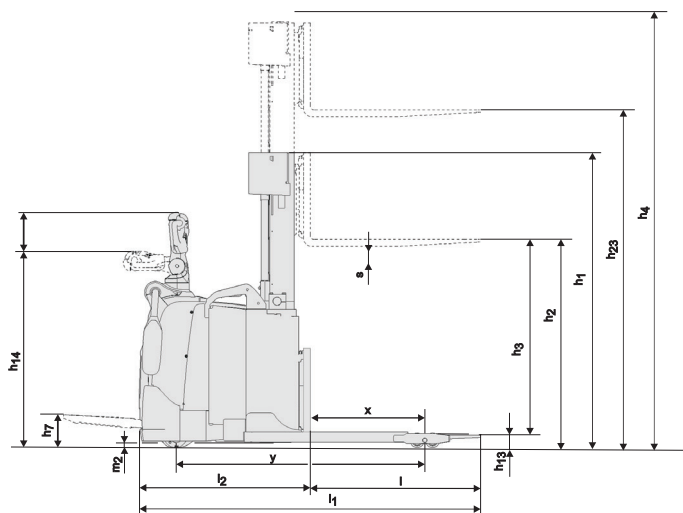

Truck features:

- BT Powertrak traction system
- Optimized Truck Performance
- Fingertip controls
- Electronic braking system
- Electronic speed control
- Operator safety
- Storage compartments
- Automatic switch-off
- Programmable performance
- Easy access for maintenance
- Sensilift
- Toyota I_site: truck fleet management system (option)
- Hydraulic oil for low temperatures (option)