

Hand pallet truck 2.0 ton

BT lifter

L-series

LHM200L/Z



Hand pallet truck

| Truck specifications | | | | | LHM200L | LHM200Z |
|----------------------|------|---|--------------------------------|----|------------------------------|---------------------------|
| Identification | 1.1 | Manufacturer | | | BT | BT |
| | 1.2 | Manufacturer's type designation | | | LHM200L | LHM200Z |
| | 1.4 | Operator type | | | Hand | Hand |
| | 1.5 | Load capacity/rated load | Q(t) | kg | 2000 | 2000 |
| | 1.6 | Load centre distance | c | mm | 600 | 600 |
| | 1.8 | Load distance, centre of drive axle to fork | x | mm | 945 ¹⁾ | 945 ¹⁾ |
| | 1.9 | Wheelbase | y | mm | 1170 ¹⁾ | 1170 ¹⁾ |
| Weight | 2.1 | Service weight | | kg | 63 | 63 |
| | 2.2 | Axle load, with load, drive/castor/fork wheel | | kg | 375/805 | 375/805 |
| | 2.3 | Axle load, without load, drive/castor/fork wheel | | kg | 20/10 | 20/10 |
| Wheels | 3.1 | Steer/fork wheels: Powerthane (Po), Steel (S) Nylon (N), Polyurethane (P), Rubber (R), Rubber antistatic (Ra) | | | S, N / S, N | Po, S, N, P, R, Ra / N |
| | 3.2 | Wheel size, front | | | 140x60 | 175x60 |
| | 3.3 | Wheel size, rear | | | 55x100 / 55x75 ²⁾ | 65x100 |
| | 3.5 | Wheels, number front/rear (x=driven wheels) | | | 2/2 or 2/4 ²⁾ | 2/2 |
| | 3.6 | Track width, front | b ₁₀ | mm | 132 | 132 |
| | 3.7 | Track width, rear | b ₁₁ | mm | 364 | 364 |
| Dimensions | 4.4 | Lift | h ₃ | mm | 70 | 115 |
| | | Lift height | h ₂₃ | mm | 125 | 180 |
| | 4.9 | Height of tiller in drive position, min./max. | h ₁₄ | mm | 1202 | 1220 |
| | 4.15 | Height, lowered | h ₁₃ | mm | 55 | 65 |
| | 4.19 | Overall length | l ₁ | mm | 1500 | 1500 |
| | 4.20 | Length to face of forks | l ₂ | mm | 365 | 365 |
| | 4.21 | Overall width | b ₁ /b ₂ | mm | 520/685 ³⁾ | 520/685 ³⁾ |
| | 4.22 | Fork dimensions | s/e/l | mm | 45/156/1150 ⁴⁾ | 45/156/1150 ⁴⁾ |
| | 4.25 | Width over forks | b ₅ | mm | 520/685 ³⁾ | 520/685 ³⁾ |
| | 4.32 | Ground clearance, centre of wheelbase | m ₂ | mm | 10 | 20 |
| | 4.33 | Aisle width for pallets 1000 x 1200 crossways | A _{st} | mm | 1525 ¹⁾ | 1525 ¹⁾ |
| | 4.34 | Aisle width for pallets 800 x 1200 lengthways | A _{st} | mm | 1725 ¹⁾ | 1725 ¹⁾ |
| | 4.35 | Turning radius | W _a | mm | 1370 ¹⁾ | 1370 ¹⁾ |

1) Distance with forks raised

2) Singel wheel / Boggie wheel

3) Other widths available on request

4) Other fork lenght available: 800/910/1000/1070/1220

All data are based on table configuration. Other configurations may give other values.

Truck performance and dimensions are nominal and subject to tolerances.

Specifications are subject to change without notice.

Dimensional drawings

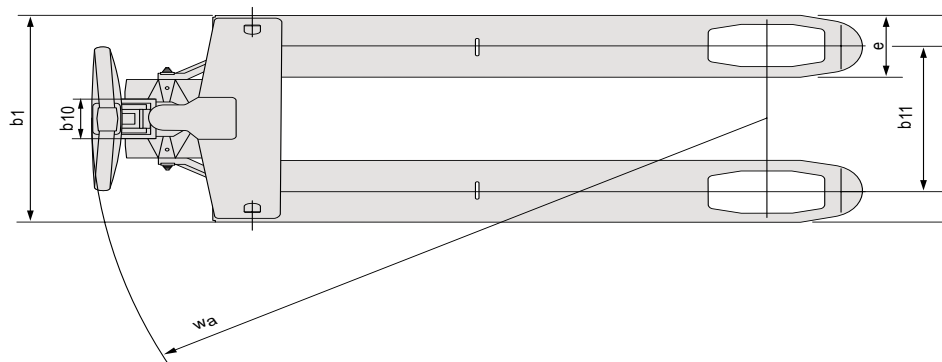
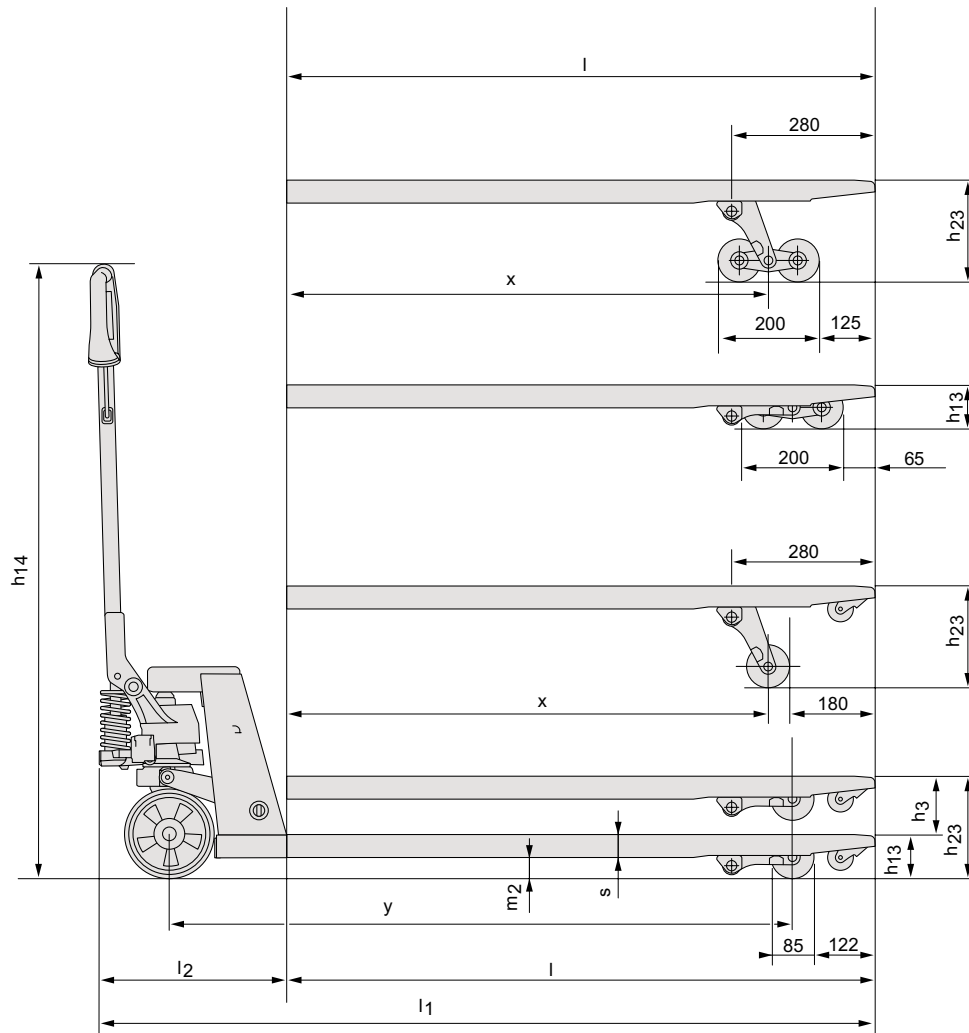

Truck features:

- Robust design and still low weight – easy to manoeuvre.
- Powder coating and robot welding give a high and even finish.
- Angled high strength polymer handle for best ergonomic grip.
- BT lowering control valve enables smooth, controlled lowering action.
- Strong powerful thrust bearing is standard, for easier steering and enhanced durability.
- Greasable bushings ensure long service life.
- Quick lift and overload can be combined.

- This product has been environmentally declared and is certified to ISO 14020.
- Customized configurations – a part of our offer.

